

IR Low Speed Dome Camera

User's Manual

- Please read the manual carefully before installing and using the unit. ●

Table of the Contents

I. Introduction.....	3
II. Technical Data.....	3
III. Characteristics.....	4
IV. Description of Functions.....	4
V. Installation and Connection of the Device.....	6
5.1 Outer-shape and Dimension.....	8
5.2 Preparation for the Installation.....	9
5.3 Installation of Wall-mount IR Low-speed Dome Camera.....	10
5.4 Installation of Pendant-mount IR Low-speed Dome Camera.....	13
VI. Configure the system of the IR Low-speed Dome Camera.....	13
6.1 Configure Protocol.....	13
6.2 Configure Baud Rate.....	13
6.3 Configure Address.....	13
VII. Basic functions of the IR Low-speed Dome Camera.....	17
7.1 Power on and self-examining of the unit.....	17
7.2 Configure and invoke Preset Positions.....	19
7.3 Configure and run Tour Group.....	20
7.4 Configure and start Left & Right scan.....	20
7.5 Start 360° endless scan.....	22
7.6 Stop Left & Right scan and 360° scan.....	22
7.7 Configure, Activate and Idle the Default Position function.....	22
7.8 Open and close the menu of camera module.....	22
VIII. Table for the Functions of the IR Low-speed Dome Camera.....	25
VIV. Trouble Shooting Table.....	26

Important Safeguards

1. During the course of transportation and storage, the product should be avoided from incorrect operations such as heavy pressing, strong vibration, soaking etc, which may cause damage to the unit.
2. The product is designed for Wall-mount and Pendant-mount installation, so it can not be installed upside-down. And the module should be handled properly so as not to bring about mechanical problems affecting the integrative functions of it.
3. Do not let any foreign objects or liquid infiltrate into the unit, which may damage the unit.
4. Please follow all electrical standards for safety when the unit is being connected and please adopt the particular power supply which is provided with the unit. The product's RS-485 and video signal adopt TVS-class lightning damage preventing technology, which can effectively prevent such pulse signal damage caused by lightning under 500W or electric surge. RS-485 and video signal should be kept enough distance from high voltage equipments and cables when they are in transmission, and necessary steps should be taken to prevent lightning damage or power surge.
5. No matter the unit is running or not, the camera module should never be aimed at the sun or other object with extremely bright light. Otherwise, the camera module's CCD might be permanently damaged.
6. There are no parts inside the unit which can be repaired by the users themselves. When mechanical problems arise, do not be in a haste to do any repairing, please refer to the User's Manual to find the trouble. If causes can not be located, please refer servicing to qualified professionals. All servicing must be done by authorized personnel.

I. Introduction

Adopting latest technological achievements and cutting-edge manufacturing techniques, the IR Low-speed Dome Camera is created with many years of accumulated experience. Equipped with a high performance DSP camera module with zooming lens, integrating built-in Pan/tilt and digital decoder, it represents the future trend of hi-tech monitoring products. The unit is capable of freely positioning, consecutively tracing and scanning, which realizes real all-directional monitoring. The unit can automatically adapt to ambient brightness and object distance. Its digital control and elegantly simple design maximally reduces the connection between different parts in the system, which improves the reliability of the system and facilitate the installation and maintenance. Driven by a stepper electric motor, the unit runs smoothly, reacts quickly and locates positions accurately. At the same time, the unit has multiple intelligent functions such as: Preset Position, Tour, Left & right scan, 360° scan, Default Position etc.

The IR lamp of the IR Low-speed Dome Camera adopts the latest LED Array technology, LED Array features higher brightness, longer visible distance, more evenly distributed light field, much longer lifespan and very little attenuation, with which the night-vision effect is greatly improved.

With varieties of high-performances, the IR Low-speed Dome Camera can be applied in every walk of life to monitor moving objects in large areas, such as monitoring smart buildings, bank, city streets, power system, airports, bus/railway stations etc.

II. Technical Data

Power Supply	DC15V (4A) (Adapter should be within 2 meters to the unit)
Working Temperature	-30℃ ~ +60℃

Relative Humidity	0~90%
Power Consumption	30W
Communication Protocol	PELCO_D / PELCO_P / PELCO_D1
Communication System	RS485 bus cable
Communication Bardrate	1200 / 2400 / 4800 / 9600bps
Address range	001~255
Horizontal Moving Speed	6°~14°/S
Vertical Moving Speed	6°~14°/S
Movement range	Pan 360° endless / Tilt 0°~90°
Preset Positions	64
Left & Right Scan	Beginning and end position can be set freely
Tour Group	4 groups / 16 Preset Positions for each/dwelling time at each preset position can be set.
360° Scan	Vertical Angle can be set freely
IR Lamp	LED Array / 2 Groups / Visible distance reaches 100m
IR Lamp Triggering	Triggered by photosensitive resistor (Default) / triggered by camera module (IR Lamp turned on when camera module turns to Black & White mode)
Protecting Grade	IP66
Weight	6.1Kg

III. Characteristics

- ◆ Latest LED Array technology adopted for IR lamps, LED Array has higher brightness, longer visible distance (over 100m), more evenly distributed light field and much longer lifespan.
- ◆ In-built module programme can automatically identify 5 brands of camera modules including LG, SONY, HITACHI, CNB, KPC.
- ◆ Adopting multi-functional high-performance DSP design with stable performance
- ◆ Integrated design with compact structure and high reliability
- ◆ Precise electric motor driver ensuring smooth running and agile reaction
- ◆ The internally saved data will not lose within a short period of time (1

- ◆ 64 preset positions for random storage and accurate locating
- ◆ 4 tour groups, 16 preset positions can be included in each tour group
- ◆ Support Left & Right scan and 360° scan function
- ◆ Support Default Position function
- ◆ Support round-the-clock (24hours per day) monitoring, at night, the unit automatically converts to Black&White mode, and the IR lamp automatically turns on.
- ◆ Power-off operation resuming function
- ◆ Automatic Iris, Focus and White Balance

IV. Description of Functions

1. IR Lamp

(1) The latest LED Array technology is adopted for this IR Low-speed Dome Camera. LED Array is highly integration of traditional LED. Comparing with traditional LED, it has some advantages as below.

A. Higher brightness: Since LED Array is integration of LED, the brightness and the viewing distance are greatly increased, the visible distance for this unit is up to 100m or so.

B. Longer lifespan, due to the difference of the transparent material and the heat-dispersion effect, the life span of the LED Array is about 10 times as the traditional LED and the attenuation is far less than traditional LED.

C. More evenly distributed light: The half-intensified beam angle of the traditional LED is about 10°, well it is 10°-120° (variable angle) for LED Array, which together with multi-angle disposal make the light evenly distributed and can light the whole room without “Flashlight” effect.

(2) There are two groups of IR lamps, users can set the triggering factor of the IR lamps as Photosensitive Resistance or the Day/night Conversion of the camera module.

2. Trace the Target

The users can control the movement of the pan/tilt by operating the joystick of the keyboard so that they can trace the moving object or change the monitoring area. The angle of view or the size of the image of the object can be changed through adjusting the focal length. In the default Auto-focus, Auto Iris state, following the movement of the pan/tilt, the lens will quickly adjust itself to get clear image according to the change of the object.

3. Automatic Adjustment of Focal Length/Movement Speed

When the focus is long and the unit is in under manual operation, due to the high sensitivity of the IR Low-speed Dome Camera, even the slightest movement of the joystick would make the image move quickly, which causes image losses. Based on human design, the unit can automatically adjust the horizontal and vertical moving speed of the pan/tilt according to the current focal-length, which makes the manual target-tracing operation much easier.

4. Color/B&W auto conversion

Designed for round-the-clock (24hours a day) monitoring. In the daytime, the image is color, well, at night, it automatically turns to Black&White, at the same time, the IR Lamp is turned on.

5. Configure and Invoke Preset Positions

The preset position function works in this way: the IR Low-speed Dome Camera saves the parameters of the current pan/tilt angel and zooming ratio of the lens under a representing number, quickly invoke those parameters when needed, the unit will turn to the corresponding position and be adjusted

to corresponding zooming ratio. The user can quickly and conveniently invoke the preset position with the controlling keyboard. The IR Low-speed Dome Camera supports 64 preset positions.

6. Automatic Tours

The automatic tour function is a built-in function of the IR Low-speed dome camera. According to actual requirement, the user can arrange the preset positions into the automatic tour in the desired order, then, the user can use such equipment as controlling keyboard to make the IR Low-speed dome camera automatically move as per the order of the preset positions set in the tour with stipulated time intervals.

- Automatic tour among preset positions can be realized through grouping together the preset positions into the tour.
- The tour order is programmable. The staying time at each preset position can be configured.
- Sixteen preset positions can be stored in one tour. Altogether 4 tours can be configured with the speed dome.

7. Left & Right Scan

Left/right limiting positions can be set through controlling keyboard, and the IR Low-speed Dome Camera can automatically scan horizontally between the left limiting position and the right limiting position, at the pre-set speed.

8. 360° Scan

360° Scan is available with the IR Low-speed Dome Camera. After adjusting the vertical angle and the zooming times well, the user can run the 360° endless Scan through invoking easy command.

9. Default Position Function

The unit supports default position function. The user can configure default position for a key monitoring area according to actual conditions. If not operated after 2 minutes, the IR Low-speed Dome Camera will automatically turn to the default position and monitor.

10. Power-off Operation resuming function

If the unit is carrying out Preset Position, Default Position, Left & Right Scan, Tour, 360° Scan etc functions, when the power is off, then, when the power is on, the unit will resume carrying out the functions after it finishes the self-examining.

11. Control the lens of the Camera Module

Focal Length Control

Users can adjust the Focal-length through controlling the keyboard to get panoramic view or close view that they desire.

Focus Control

The system takes auto-focus as the default. While moving, the camera module can automatically focus on the center of the object view to get clear image. Under special circumstances, the user can manually adjust the focus to achieve desired image effect.

- Manual focus can be realized through controlling the keyboard or matrix. For details, please refer to the operation manual of the controlling keyboard or matrix.
- In the state of manual focus, the user can control focal-length to make the lens focus on the object. If the IR Low-speed Dome Camera is configured to automatically resume auto-focus upon joystick operation, when there is operating on the joystick, the IR Low-speed Dome Camera will automatically focus. If a period of time is configured for auto-focus resuming, once there is

no controlling order received, after the period of time, the IR Low-speed Dome Camera will resume auto-focus.

Under the following circumstances, the camera module can not carry out auto-focus:

- When the object is not in the center of the view.
- When simultaneously observe a far object and a near one, clarity for both of the images can not be guaranteed at the same time.
- When observing objects with extreme brightness, such as neon lights, spotlight, etc
- When the object is behind the glass with water drops or dust
- When the object moves very fast
- When the object is large-sized and drab, such as wall
- When the object is too dark or fuzzy

Iris Control

- The system takes auto-iris as the default. The iris can automatically sense the change of the environmental light and make quick adjustment, so that the brightness of the image is stable.
- The user can manually adjust the iris through controlling the keyboard to obtain desired brightness for the image.

12. Automatic Back Light Compensation (BLC)

Automatic Back Light Compensation can be realized via district dividing. In extremely bright background, the camera module can compensate the brightness of the relatively dark objects, while adjust the light of the bright background, avoiding that the whole image is too bright to watch due to the too high brightness of the background while the object is too dark to be distinguished, so that the clear image can be got.

13. Automatic White Balance

According to the ambient brightness, the camera module can automatically adjust the White Balance to re-display the real color.

V. Installation and Connection of the device

5.1 Outer-shape and Dimension

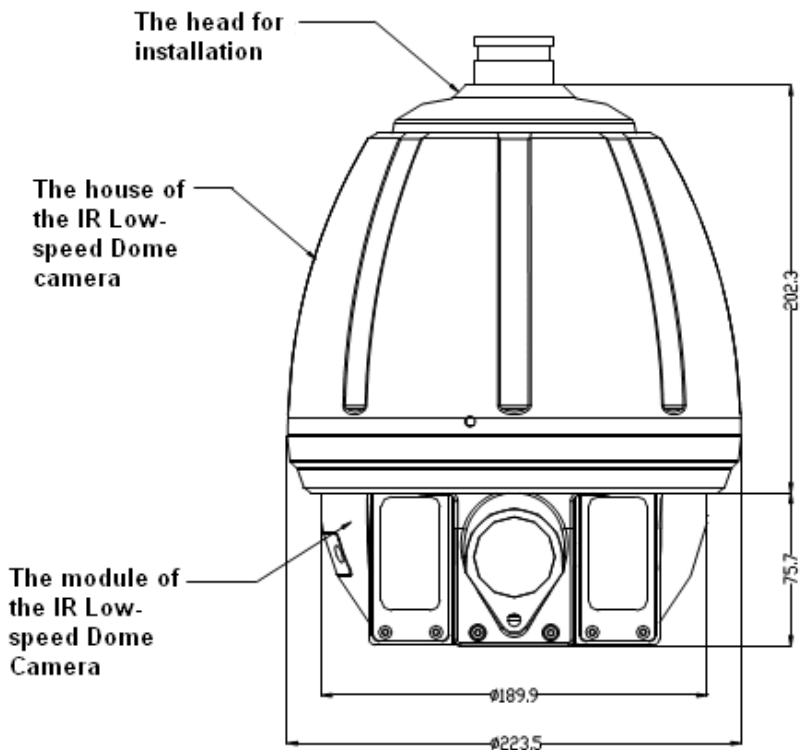

5.2 Preparation for the Installation:

1. To avoid mistakes, installation must be done by qualified personnel conforming to related regulations.
2. Please check whether the attachments are all ready, and whether the installing location and style of installation are compatible.
3. The IR Low-speed dome camera is composed of bracket, housing, module, power adaptor, installing screws etc.
4. When the IR Low-speed dome camera leaves factory, it has undergone installation testing, so the user can directly carry out the installation.
5. Before installation, please carefully read the instruction for installation in the User's Manual which is enclosed with the unit.

5.3 Installation of Wall-mount IR Low-speed Dome Camera

5.3.1 Installation of Wall-mount Bracket

Attention: The wall for the selected installation location must be firm without peeling. To avoid quivering images resulting from unstable installation, make sure the place for installation can sustain five times the total weight of the IR Low-speed Dome Camera, the bracket and the base.

A. Use the bottom installation board of the bracket as template and draw the positions of the installing holes on the desired wall locus;

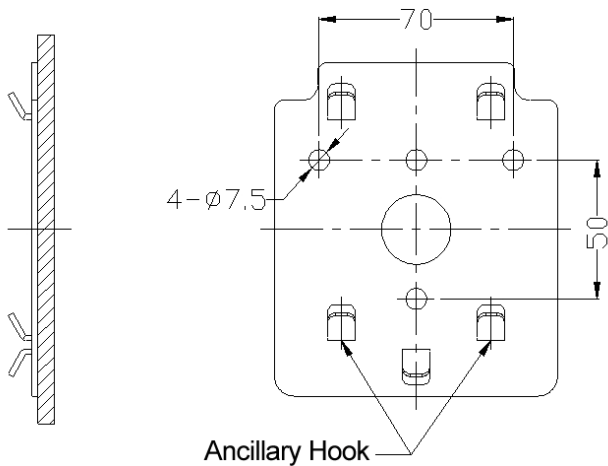

Wall Bracket Installation Dimensions

- B. Use an electrical drill to make four holes for M6 screws on the above-drawn positions, and drive in the expansion M6 screws;
- C. Fix the installation board of the bracket firmly on the wall with four M6 screw nuts and washers.
- D. Push the power cable, communication cable and video cable through the bracket tube, then push the installing port on the top of the outer housing into the installing hole of the bracket, tighten the 3 M6 screws and fix well. Make sure the M6 screws just fit in the screw slot of the installing port of the housing. (See the picture below)

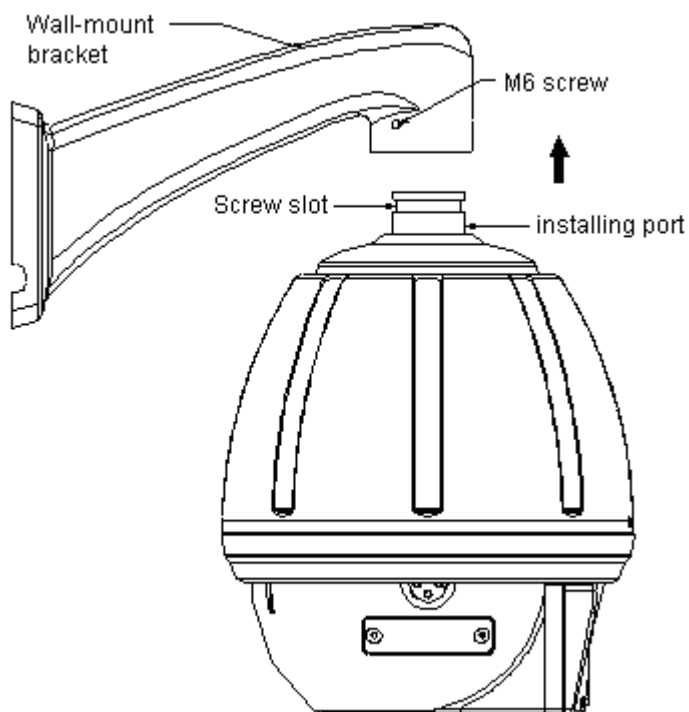

E. Put the power adaptor into the wall bracket and pin the power adaptor with the adaptor pinning board, lest the power adaptor slides out. (See the figure below)

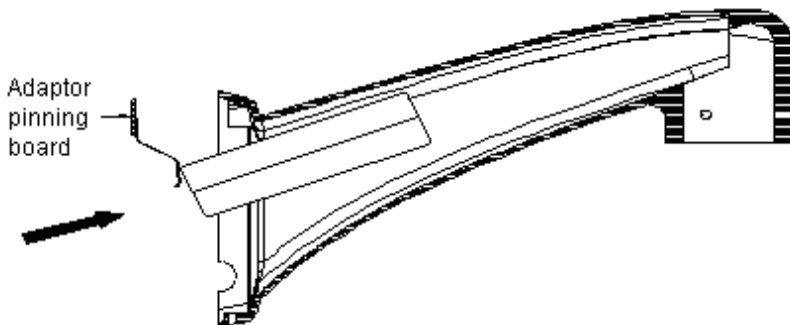

Attention: The adaptor equipped can only be placed indoor or in water-proof box or other water-proof spaces, it can not be placed directly outdoor, otherwise water may seep in and damage the adaptor.

F. Put up the wall bracket assembled with IR Low-speed dome on the ancillary hooks: Pull the power cable, video cable and controlling cable out through the wire-out-going hole of the bracket, then put the assembled on the two corresponding pegs on the installed peg-board, then push the bracket downward until it locks in place. Make sure the wall bracket is well fixed with the installation board, then direct the screw on the bracket to the corresponding hole on the lower part of the installation board and tighten the screw.

5.3.2 Connection of Exterior Cables

Connect BNC video outlet of the IR Low-speed Dome Camera with the already disposed video cable, the power cable with the already disposed power cable (DC15V) and RS485 controlling cable with already disposed RS485 controlling cable. The cables of IR Low-speed dome camera is shown below:

Cable	Application	Connecting Objects	Remarks
-------	-------------	--------------------	---------

Power cable	DC15V power supply	IR Low-speed dome--- power supply adaptor	Inner positive, outer negative
485 cable	485 controlling signal	IR Low-speed dome --- controlling device	Green (A), white(B)
Video Cable	video signal	IR Low-speed dome ---monitoring device	Inner positive, outer negative
Earth connecting port	Connecting the earth for lightening proof	IR Low-speed dome --- the earth	Black cable

- ◆ When connecting, make sure the polarity of RS485 controlling cable is correct: A: RS485 positive, B: RS485 negative.
- ◆ If wrongly connected, the IR Low-speed Dome Camera will be out of control.

5.3.3 Switch on Power

- a Make sure the polarity of plugs, sockets and the connection of cables is correct, then switch on power
- b The IR Low-speed Dome Camera begins to do the self-check: it moves pan 360°, tilt 90°, then moves to its original position, then zooms in and zooms out once. Through the self-check, the unit checks the mechanical moving performance of the pan/tilt, the electrical performance of the controlling system, the controlling of the camera module. After the IR Low-speed Dome Camera finishes self-check, it stays at the original position and is ready to receive controlling instructions.
- c Use controlling device to control the IR Low-speed Dome Camera, checking whether it can perform the functions of the pan/tilt and the lens of the camera module. If not, please check the configuration of communication protocol, Baud rate and address, and the connection of 485 controlling cable.

5.4 Installation of Pendant-mount IR Low-speed Dome Camera

5.4.1 Installation of Pendant-mount Bracket

Remarks: The ceiling for the selected installation location must be firm without peeling. To avoid quivering images resulting from unstable installation, make sure the place for installation can sustain five times the total weight of the IR Low-speed Dome Camera, the bracket and the base.

A Use the bracket as template and draw the positions of the installing holes on the desired ceiling locus;

B Use an electric drill to make three holes for M6 screws on the above-drawn positions, and drive in the special M6 screws;

C Push the power cable, communication cable and video cable through the bracket tube, then push the installing port on the top of the outer housing of the unit into the installing hole of the bracket, tighten the 3 M6 screws and fix well. Make sure the M6 screws just fit in the screw slot of the installing port of the housing;

D Put the power adaptor into some installing box, fix the adaptor well lest it slides out.

Attention: The adaptor equipped can only be placed indoor or in water-proof box or other water-proof spaces, it can not be placed directly outdoor, otherwise water may seep in and damage the adaptor

E Pull the power cable, video cable and controlling cable out through the cable slot of the bracket, leaving long enough cables for connection;

F Fix the bracket firmly on the ceiling with three M6 screw nuts and washers.

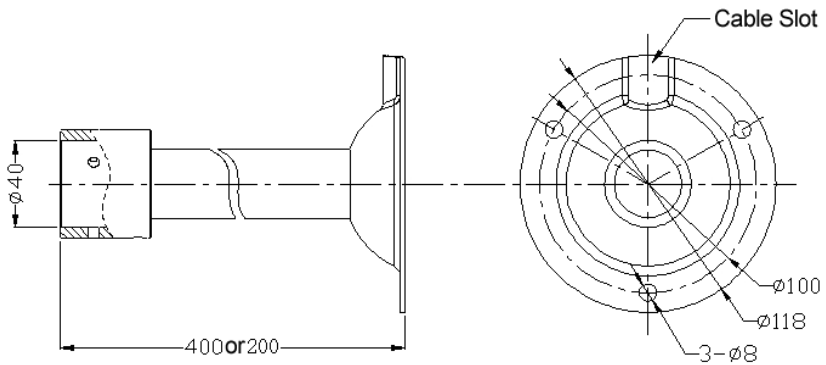

5.4.2 Connection of Exterior Cables

Connect BNC video outlet of the IR Low-speed Dome Camera with the already disposed video cable, the power cable with the already disposed power cable (DC15V) and RS485 controlling cable with already disposed RS485 controlling cable. The cables of IR Low-speed dome camera is shown below:

Cable	Application	Connecting Objects	Remarks
Power cable	DC15V power supply	IR Low-speed dome--- power supply adaptor	Inner positive, outer negative
485 cable	485 controlling signal	IR Low-speed dome --- controlling device	Green (A), white(B)
Video Cable	video signal	IR Low-speed dome ---monitoring device	Inner positive, outer negative
Earth connecting port	Connecting the earth for lightening proof	IR Low-speed dome --- the earth	Black cable

◆ When connecting, make sure the polarity of RS485 controlling cable is correct: A: RS485 positive, B: RS485 negative.

- ◆ If wrongly connected, the IR Low-speed Dome Camera will be out of control.

5.4.3 Switch on Power

- a Make sure the polarity of plugs, sockets and the connection of cables is correct, then switch on power
- b The IR Low-speed Dome Camera begins to do the self-check: it moves pan 360°, tilt 90°, then moves to its original position, then zooms in and zooms out once. Through the self-check, the unit checks the mechanical moving performance of the pan/tilt, the electrical performance of the controlling system, the controlling of the camera module. After the IR Low-speed Dome Camera finishes self-check, it stays at the original position and is ready to receive controlling instructions.
- c Use controlling device to control the IR Low-speed Dome Camera, checking whether it can perform the functions of the pan/tilt and the lens of the camera module. If not, please check the configuration of communication protocol, Baud rate and address, and the connection of 485 controlling cable.

VI. Configure the system of the IR Low-speed Dome Camera

Before the installation of the IR Low-speed Dome Camera, you must confirm if the protocol, the Baud rate of the controlling system and the address code of the IR Low-speed dome camera is right (the factory default is: Pelco_D for protocol, 4800bps for baudrate, 001 for address code). You must make sure that the configuration of them must be identical to that of the

controlling device. The corresponding switches for configuration is shown in the following figure:

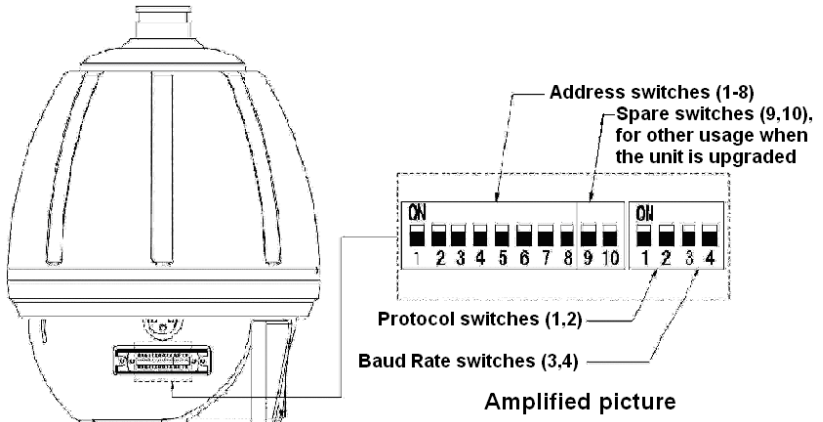

6.1 Configure Protocol

The DIP-1 and DIP-2 of the 4-button switch on the PCB board is for communication protocol configuration. Please refer to the following table:

NO.	2 1	PROTOCOL
1	0 0	PELCO_D
2	0 1	PELCO_P
3	1 0	JCO
4	1 1	PELCO_D1

If the controlling device could only support the preset position numbers below 128, please use PELCO_D1 controlling protocol.

6.2 Configure Baud Rate

DIP-3 and DIP-4 of the 4-button switch on the PCB board is used to

configure Baudrate of communication, the default configuration is 4800BPS. Following table shows states of coding switches and corresponding Baudrate.

No.	4 3	Baudrate
1	0 0	1200 BPS
2	0 1	2400 BPS
3	1 0	4800 BPS
4	1 1	9600 BPS

Remark: If the IR Low-speed Dome Camera is used at the farthest terminal, there should be a parallel connection of a 120Ω terminal matching resistor between A, B lines of RS485.

6.3 Configure Address

Before actual operating of the unit, the address of the IR Low-speed dome camera should be configured. The buttons from DIP-1 to DIP-8 of the 10-button Switch are used to set address of the IR Low-speed Dome Camera from 1 to 255. The coding switches from DIP-1 to DIP-8 are equivalent to a 8-bit binary figure. The state "ON" of each bit means "1" while "OFF" means "0". Corresponding state of coding switches and address is shown in the table below:

Correspondence of Address and Coding Switch (DIP1-DIP8 of the 10-button switch)

NO	87654321	NO	87654321	NO	87654321
1	00000001	32	00100000	63	00111111
2	00000010	33	00100001	64	01000000
3	00000011	34	00100010	65	01000001

4	00000100	35	00100011	66	01000010
5	00000101	36	00100100	67	01000011
6	00000110	37	00100101	68	01000100
7	00000111	38	00100110	69	01000101
8	00001000	39	00100111	70	01000110
9	00001001	40	00101000	71	01000111
10	00001010	41	00101001	72	01001000
11	00001011	42	00101010	73	01001001
12	00001100	43	00101011	74	01001010
13	00001101	44	00101100	75	01001011
14	00001110	45	00101101	76	01001100
15	00001111	46	00101110	77	01001101
16	00010000	47	00101111	78	01001110
17	00010001	48	00110000	79	01001111
18	00010010	49	00110001	80	01010000
19	00010011	50	00110010	81	01010001
20	00010100	51	00110011	82	01010010
21	00010101	52	00110100	83	01010011
22	00010110	53	00110101	84	01010100
23	00010111	54	00110110	85	01010101
24	00011000	55	00110111	86	01010110
25	00011001	56	00111000	87	01010111
26	00011010	57	00111001	88	01011000
27	00011011	58	00111010	89	01011001
28	00011100	59	00111011	90	01011010
29	00011101	60	00111100	91	01011011
30	00011110	61	00111101	92	01011100
31	00011111	62	00111110	93	01011101

N0	87654321	N0	87654321	N0	87654321
94	01011110	125	01111101	156	10011100
95	01011111	126	01111110	157	10011101
96	01100000	127	01111111	158	10011110
97	01100001	128	10000000	159	10011111

98	01100010	129	10000001	160	10100000
99	01100011	130	10000010	161	10100001
100	01100100	131	10000011	162	10100010
101	01100101	132	10000100	163	10100011
102	01100110	133	10000101	164	10100100
103	01100111	134	10000110	165	10100101
104	01101000	135	10000111	166	10100110
105	01101001	136	10001000	167	10100111
106	01101010	137	10001001	168	10101000
107	01101011	138	10001010	169	10101001
108	01101100	139	10001011	170	10101010
109	01101101	140	10001100	171	10101011
110	01101110	141	10001101	172	10101100
111	01101111	142	10001110	173	10101101
112	01110000	143	10001111	174	10101110
113	01110001	144	10010000	175	10101111
114	01110010	145	10010001	176	10110000
115	01110011	146	10010010	177	10110001
116	01110100	147	10010011	178	10110010
117	01110101	148	10010100	179	10110011
118	01110110	149	10010101	180	10110100
119	01110111	150	10010110	181	10110101
120	01111000	151	10010111	182	10110110
121	01111001	152	10011000	183	10110111
122	01111010	153	10011001	184	10111000
123	01111011	154	10011010	185	10111001
124	01111100	155	10011011	186	10111010

NO	87654321	NO	87654321	NO	87654321
187	10111011	210	11010010	233	11101001
188	10111100	211	11010011	234	11101010
189	10111101	212	11010100	235	11101011
190	10111110	213	11010101	236	11101100
191	10111111	214	11010110	237	11101101

192	11000000	215	11010111	238	11101110
193	11000001	216	11011000	239	11101111
194	11000010	217	11011001	240	11110000
195	11000011	218	11011010	241	11110001
196	11000100	219	11011011	242	11110010
197	11000101	220	11011100	243	11110011
198	11000110	221	11011101	244	11110100
199	11000111	222	11011110	245	11110101
200	11001000	223	11011111	246	11110110
201	11001001	224	11100000	247	11110111
202	11001010	225	11100001	248	11111000
203	11001011	226	11100010	249	11111001
204	11001100	227	11100011	250	11111010
205	11001101	228	11100100	251	11111011
206	11001110	229	11100101	252	11111100
207	11001111	230	11100110	253	11111101
208	11010000	231	11100111	254	11111110
209	11010001	232	11101000	255	11111111

◆ If protocol, address and Baud rate are configured when power is on, then the IR Low-speed dome camera must be switched off and restarted to make the configuration valid.

VII. Basic functions of the IR Low-speed Dome Camera

7.1 Power on and self-examining of the unit

Once power on, the unit enters self-checking procedure: it moves pan 360°, tilt 90°, then moves to its original position, then the lens zoom from far to near, then from near to far. Through the self-check, the unit checks

the mechanical moving performance of the pan/tilt, the electrical performance of the controlling system, the controlling of the camera module. After the IR Low-speed Dome Camera finishes self-check, it stays at the original position and is ready to receive controlling instructions.

7.2 Configure and Invoke Preset Positions

The function of preset positions works in this way: the IR Low-speed Dome Camera saves the parameters of the current pan/tilt angel and zooming ratio of the lens under a representing number, quickly invoke those parameters when needed, the unit will turn to the corresponding position and be adjusted to corresponding zooming ratio. Users can use such devices as controlling keyboard to save and invoke preset positions quickly and conveniently. The IR Low-speed Dome Camera can support up to 64 preset positions.

7.2.1 Configure Preset Positions

After turning the IR Low-speed Dome Camera to desired position and adjusting to desired zooming ratio, through the keyboard, enter the number that is to represent the preset position, press the “PRESET” key. Now you have configured one preset position.

Example: Configure preset position No.1

- a. Use the joystick to move the IR Low-speed Dome Camera to the desired position and adjust the lens of the camera module well.
- b. Enter “1”
- c. Press the “PRESET” key

◆ Manual focus approach can be adopted to configure preset positions for

distant objects, that is, after adjusting the lens to focus on distant place, control the keys “FOCUS+”and “FOCUS-”on the controlling keyboard to configure optimal focal image storage to avoid fuzzy images resulting from the interference of other distant objects.

7.2.2 Invoke Preset Positions

The function enables the IR Low-speed Dome Camera to quickly return to the preset position.

Enter the number(1~64) key for preset position number which you need to invoke, the LED displays the preset position number. Then, press the “PREVIEW” key. The IR Low-speed Dome Camera will return to the preset position.

e.g. Invoke the No.1 preset position

- a. Enter “1”
- b. Press “PREVIEW” key

7.3 Configure and run tour groups

The tour group function is to group some preset positions together, if the user wants to invoke these preset positions, with only one external order, the IR Low-speed Dome Camera will automatically invoke the preset positions in the group one by one. The dwelling time at each preset position can be set within 1-255 seconds. Up to 16 preset positions can be saved in each tour group. And at most 4 tour groups can be configured. The operation is as below:

A. In the keyboard initial state, enter number “140”(110) and press the “PREVIEW” key to enter the tour configuration.

- B. After entering the configuration, add preset position number to the tour. Enter the first desired preset position number and press the “PREVIEW” key, and the first preset position is successfully added. Then goes the second one. Enter the second desired preset position number and press the “PREVIEW” key, and the second preset position is successfully added. More preset positions can be added in the same way.
- C. After all the required preset positions having been added in the tour, enter the number “141”(111) on the keyboard and press the “PREVIEW” key to exit the tour configuration.
- D. Start Running a Tour: In the keyboard initial state, enter number “142”(112) and press the “PREVIEW” key to start running the preset tour.

Example: Configure the tour order to be 1→2→5→3→4→6 (please configure preset positions before tour configuration)

1. Invoke “preset position” 140(110) to enter tour configuration (Enter number “140”(110) and press the “PREVIEW” key)
2. Invoke preset position 1 to configure the first tour position (Enter number “1” and press the “PREVIEW” key)
3. Invoke preset position 2 to configure the second tour position (Enter number “2” and press the “PREVIEW” key)
4. Invoke preset position 5 to configure the third tour position (Enter number “5” and press the “PREVIEW” key)
5. Invoke preset position 3 to configure the fourth tour position (Enter number “3” and press the “PREVIEW” key)
6. Invoke preset position 4 to configure the fifth tour position (Enter number “4” and press the “PREVIEW” key)

7. Invoke preset position 6 to configure the sixth tour position (Enter number “6” and press the “PREVIEW” key)
8. Invoke “preset position” 141(111) to finish tour configuration (Enter number “141”(111) and press the “PREVIEW” key)
9. Invoke “preset position” 142(112) to start running the tour, and the IR Low-speed Dome Camera runs the tour and begins to cruise in the order of 1→2→5→3→4→6.

If other devices are used to control the IR Low-speed Dome Camera, due to the protocol limitation, some special functions of the IR Low-speed Dome Camera may be not operational.

7.4 Configure and start Left & Right scan

The IR Low-speed Dome Camera has Left/Right scan function. The user can configure the left and right limiting positions for the required left&right scanning area. When running the left&right scan, the unit will scan forwards and backwards between the left and right limiting positions consecutively.

7.4.1 Configure Left & Right limiting positions

The user can freely set a beginning point as the Left Limiting Position, an end point as the Right Limiting Position (Attention: If the beginning point is the same as the end point, the unit will scan 360° endlessly). Meanwhile, the unit will automatically record the zooming ratio of the lens at the beginning point and take this data as the constant zooming ratio of the lens when scanning, also, the unit will record the vertical angle of the beginning point and take this angle as the constant vertical angle when scanning. The operation of configuring Left & right limiting position is as below:

1. Configure the Left Limiting Position: Operate the joystick towards left,

- A. Input 130(100)
 - B. Press PREVIEW key
2. Configure the Right Limiting Position: After the Left Limiting position is configured well, operate the joystick towards right, adjust the image to the desired position, then:
- A. Input 131(101)
 - B. Press PREVIEW key
- After configuring well, operate as below to run the scan.

7.4.2 Start Left & Right scan:

To start Left & Right scan means that the user use an external order to start the scan and to make the unit scan between two limiting positions, so that the user can monitor the corresponding district. The user can operate on the keyboard, the operation is as below:

Operation through invoking function code:

- a. Input 133(103)
- b. Press PREVIEW key

Then the IR Low-speed Dome Camera will scan between the two positions.

7.5 Start 360° endless scan

The unit can carry out 360° scan function. So that all-direction scanning and monitoring effect is realized. The user can operate on the keyboard, the operation is as below:

- a. Input 136
- b. Press PREVIEW key

Then the unit will carry out 360° endless scan.

7.6 Stop Left & Right scan and 360° scan

While the unit is carrying out Left&Right or 360° scanning operation, if you require the unit carry out other operations, you can operate on the keyboard to stop the auto scan. Operation is as below:

- a. Input 138(108)
- b. Press PREVIEW key

The Auto Scan can also be stopped by any operation on the joystick of the keyboard.

7.7 Configure, Activate and Idle the Default Position function

The unit has default position function. The user can configure default position for a key monitoring area according to actual conditions. If not operated after 2 minutes, the IR Low-speed dome camera will automatically turn to the default position and monitor.

1. Configure the Default Position

Move the IR Low-speed Dome Camera to a key monitoring area through controlling keyboard, adjust the zooming ratio well, then enter number “164”(124) from the keyboard and press the “PREVIEW” key, then the configuration is successful.

2. Activate and idle the Default Position function

The user can activate or idle the function of default position through the keyboard. Enter number “162”(122) and press the “PREVIEW” key, the function is activated. Enter number “163”(123) and press the “PREVIEW” key, the function is idled.

7.8 Open and close the menu of camera module

The unit has a function as “configuring the parameters of the Camera Module”. Users can open and close the menu of the camera module by invoking 145 and 146 “preset positions”. After entering the menu, users can configure the camera module conveniently. The operation is as below:

1. Open the menu of the camera module

- a. Input 145(95)
- b. Press PREVIEW key.

2. Close the menu of the camera module

- a. Input 146(96)
- b. Press PREVIEW key.

Attention: If the camera module doesn't have menu function, this function with the unit is unavailable.

VIII. Table for the functions of the IR Low-speed dome camera

Notice: “PELCO-D” and “PELCO-P” protocols have no corresponding orders for part of the special functions, so we converted functions of some of the commonly-used orders, generally converting in the way of “invoking preset position/ configuring preset position”. Order converting correspondence is shown in the following table:

Invoke “preset position” No.	Keyboard operation meaning	Invoke “preset position” No.	Keyboard operation meaning
---------------------------------------	----------------------------	---------------------------------------	----------------------------

130	Configure left limiting position	125	IR lamps to be triggered by photosensitive resistor
131	Configure right limiting position	126	IR lamps to be triggered by camera module
133	Start Left & right scanning	145	Enter menu of the camera Module
136	Start Pan/tilt 360° scanning	146	Exit menu of the camera Module
138	Stop Pan/tilt auto-scanning	162	Activate default position function
140	Start tour configuration	163	Idle default position function
141	Exit tour configuration	164	Configure default position function
142	Start running a tour		

If preset position numbers larger than 128 could not be invoked on the controlling device, please choose PELCO-D1 protocol, functions operation table as below:

Invoke "preset position" No.	Keyboard operation meaning	Invoke "preset position" No.	Keyboard operation meaning
100	Configure left limiting position	125	IR lamps to be triggered by photosensitive resistor
101	Configure right limiting position	126	IR lamps to be triggered by camera module
103	Start Left & right scanning	95	Enter menu of the camera Module
106	Start Pan/tilt 360° scanning	96	Exit menu of the camera Module

108	Stop Pan/tilt auto-scanning	122	Activate default position function
110	Start tour configuration	123	Idle default position function
111	Exit tour configuration	124	Configure default position function
112	Start running a tour		

Intelligent control and all of the functions of the unit can be realized through the keyboard's control over the IR Low-speed Dome Camera. Since different controlling system interfaces may differ in operation, operation details are subject to the related manufacturer's manuals. Under certain circumstances of special requirements and operations, please refer to dealers for necessary information.

VIV. Trouble Shooting Table

Problems	Possible causes	Remedies
No action, no picture, no indicator on when power is switched on.	Wrong connection of power cables	Correct
	Power supply adaptor damaged	Replace
	Fuse damaged	Replace
	Bad power cable connection	Correct
Normal self-check and image but out of control	Address or Baud rate configuration wrong	Configure again
	Protocol configuration wrong	Configure again
	RS485 bus bad connection	Check RS485 bus connection
Abnormal self-check image	Mechanical failure	Repair
	Camera Module inclined	Reinstall

with motor noise	Power supply not enough	Replace, better to place the adaptor nearby the IR Low-speed Dome Camera
Unstable image	Bad connection of video cable	Correct
	Power supply not enough	Replace
Fuzzy image	At Manual focus state	Operate the IR Low-speed Dome Camera or invoke any preset positions
	Vitreous cover dirty	Clean the vitreous cover
Some IR Low-speed Dome Camera out of control or control delayed	Power supply not enough	Replace, better to place the adaptor nearby the unit
	Whether matching resistor is in the IR Low-speed Dome Camera at the farthest end	Install matching resistor in the IR Low-speed Dome Camera
	The distance is too far, the attenuation of the signal on RS485 is too much	Replace the controlling cable with thicker one
	The driving power of the 485 converter is not enough	Replace with converter that has separate power supply